

## Baureihe SV 33-92

### *Gleitringdichtung wechseln*

**HINWEIS:** Zum Wechseln der Gleitringdichtung muss der Motor nicht demontiert werden!



**Kupplungsschutz abschrauben**

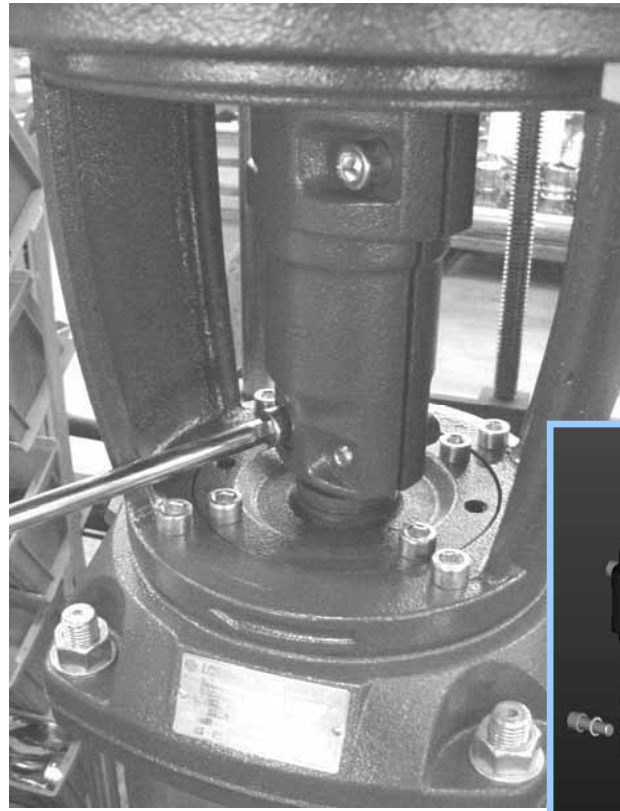
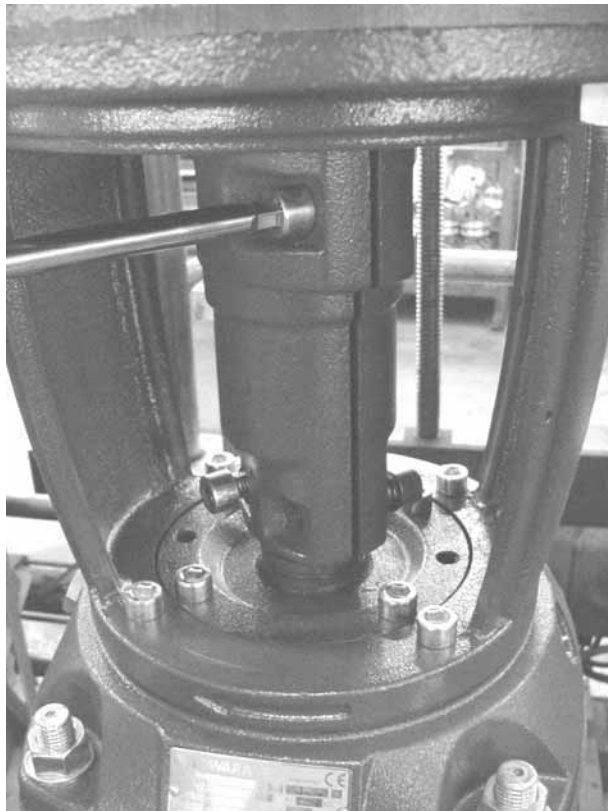

**Kupplungsschrauben lösen**

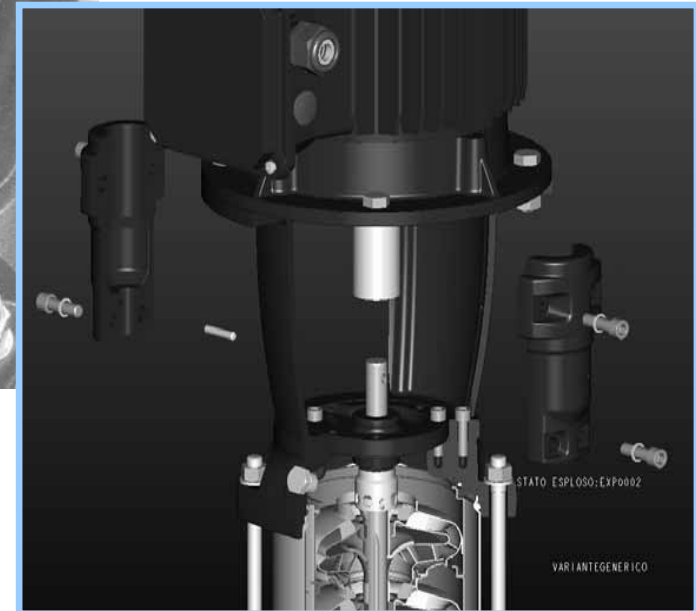

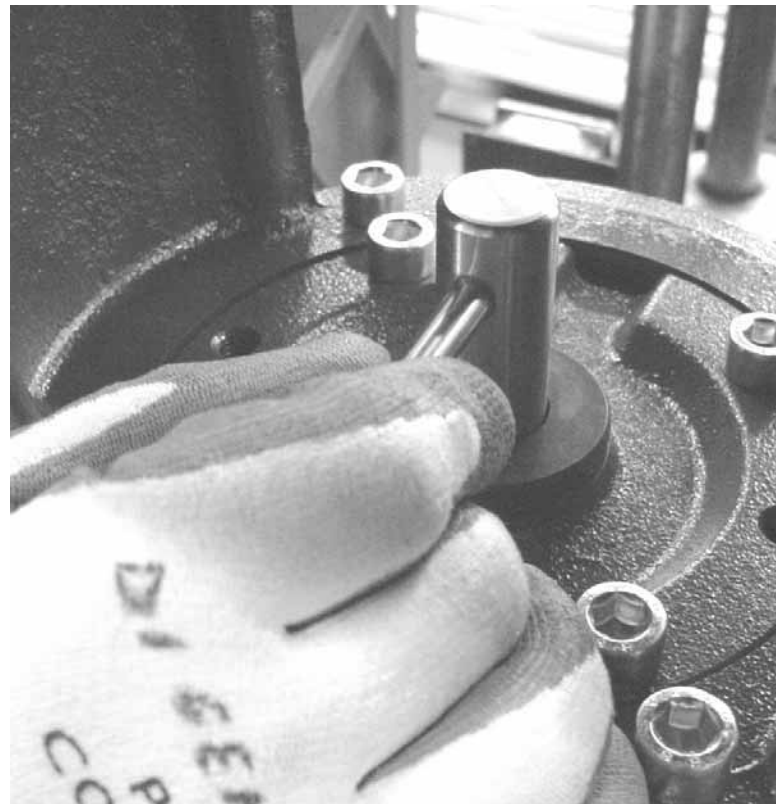

**Kupplungshälften und Mitnehmerstift ausbauen**

## Ausbau des Dichtungsdeckels

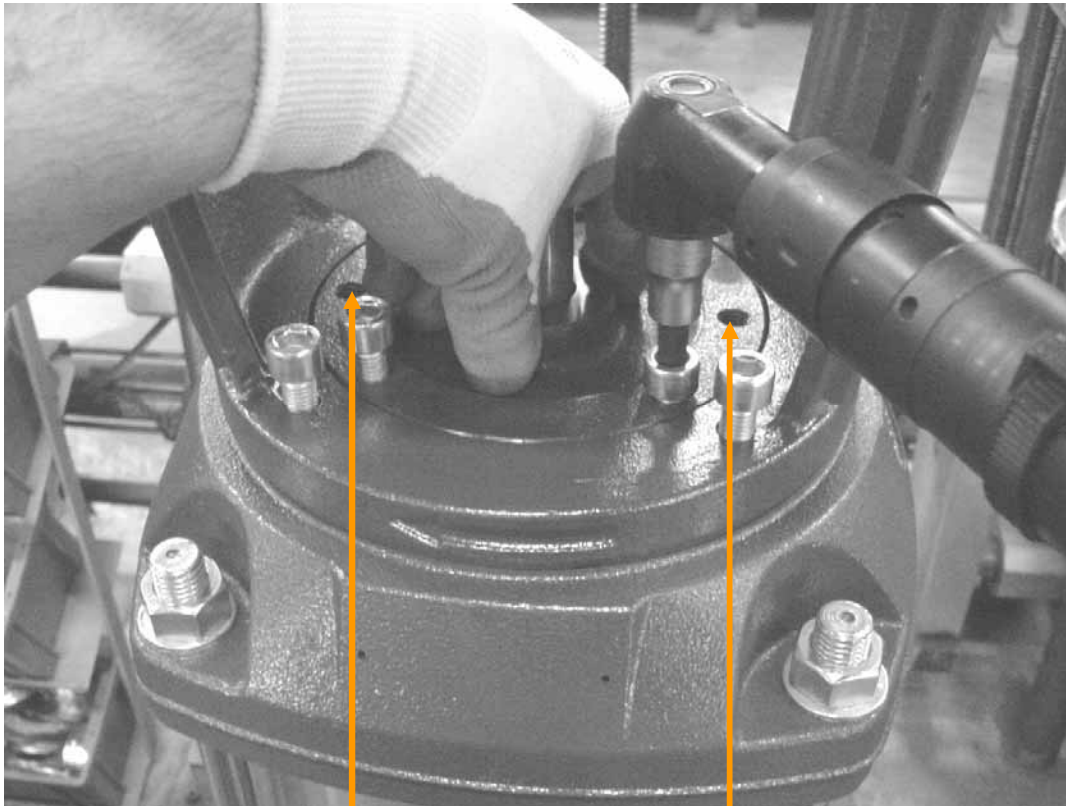

Bohrungen zum Abdrücken

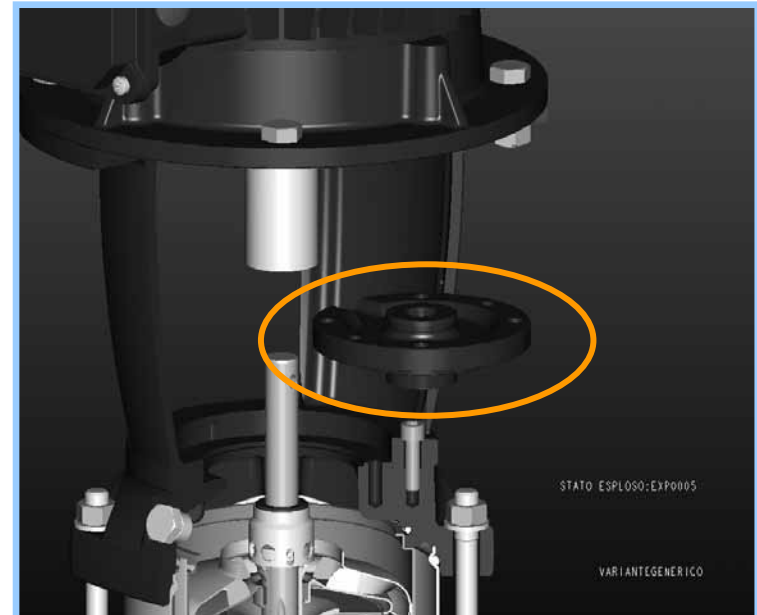



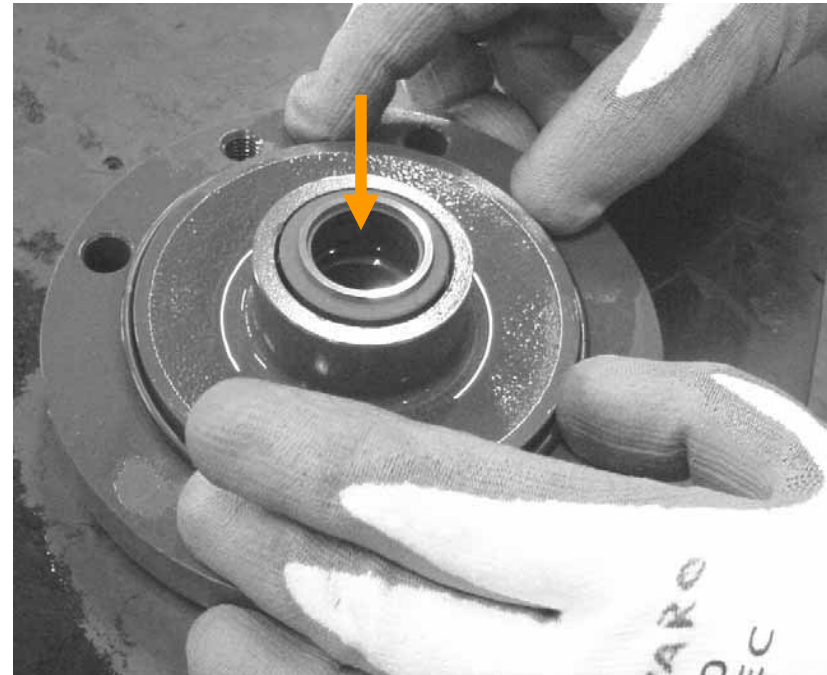
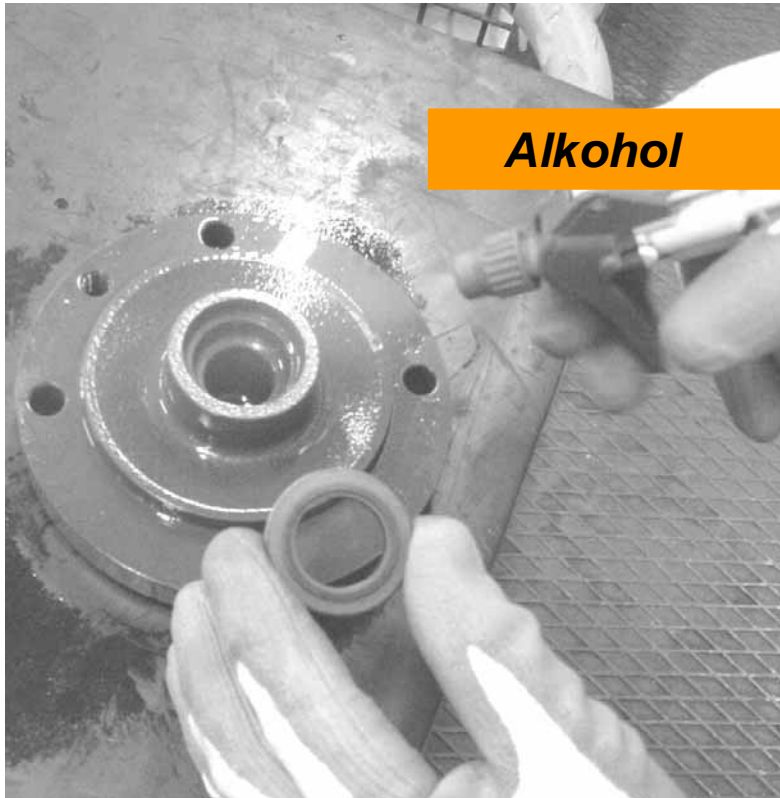

**Austausch des stationären Rings  
der Gleitringdichtung**





Mitnehmer

Bohrungen

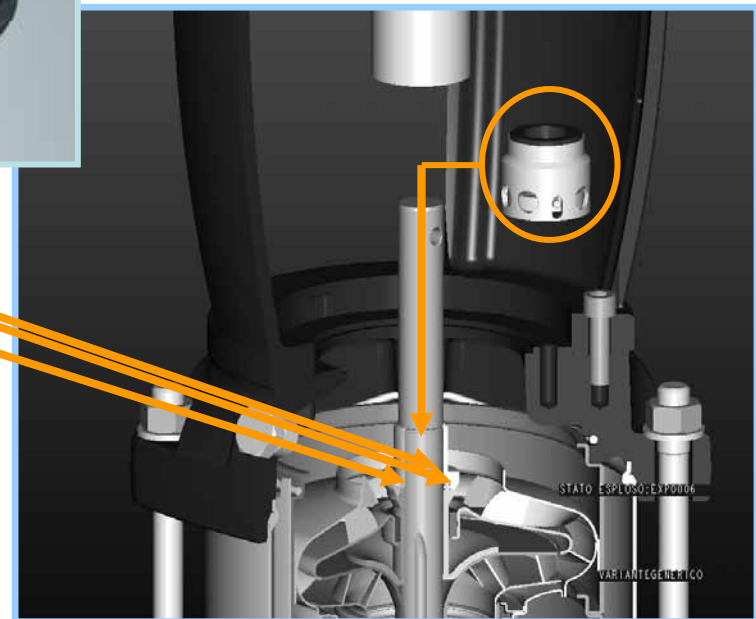

**Austausch des rotierenden Teils der Gleitringdichtung (keine Werkzeuge verwenden!)**  
Die Mitnehmerstifte müssen in den passenden Bohrungen in der Distanzhülse sitzen.



### **Einbau des Dichtungsdeckels**

**Schrauben über Kreuz anziehen, Drehmoment beachten.**



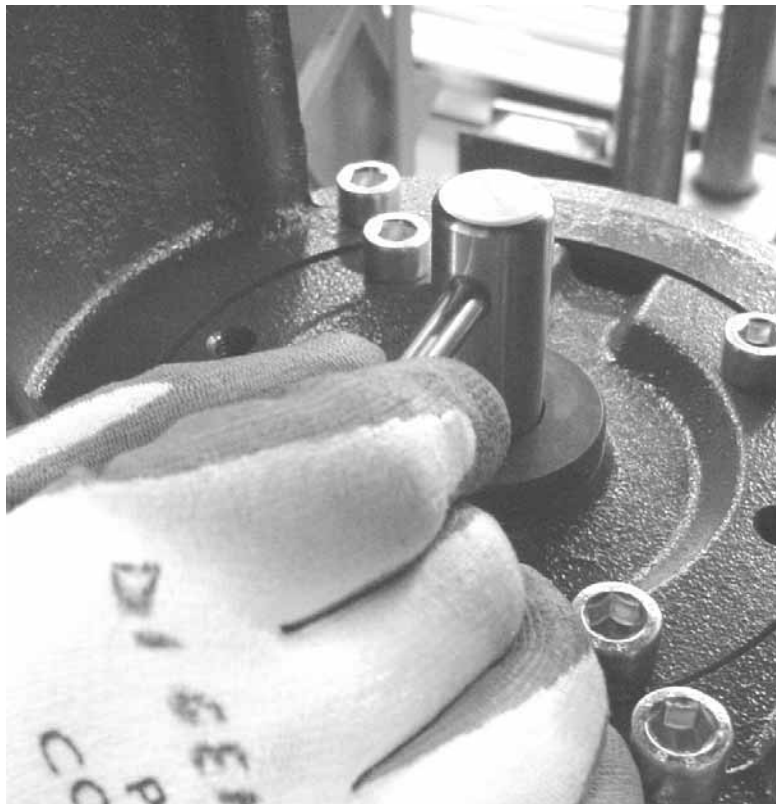

**Mitnehmerstift und Kupplungshälften einbauen**



**Welle ausrichten mit  
– 5mm Schlüssel →**

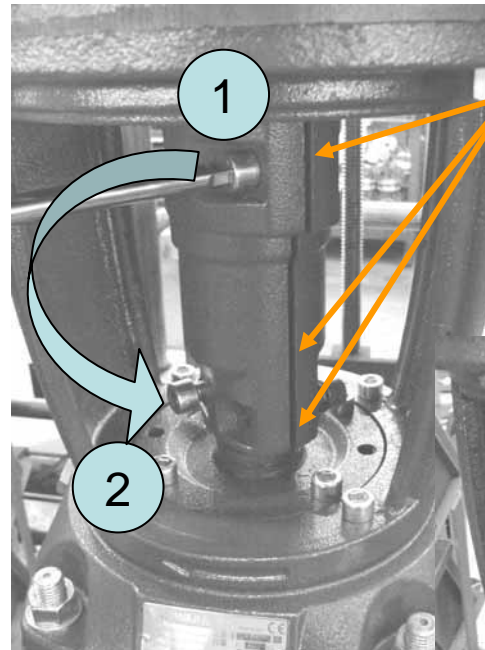

**Parallel montieren**

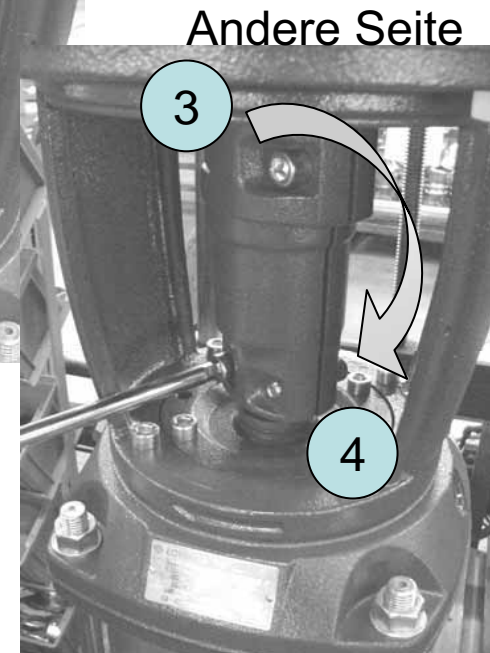

**Andere Seite**

**Kupplung  
festziehen.  
Schrauben über  
Kreuz anziehen.**



**Kupplungsschutz montieren**